

QUESTIONNER LE MONDE – TEMPS.

Exercice de recherche et de compréhension :

- 1) Je découpe les images.
- 2) Je classe les images sur la frise chronologique : des plus vieux transports aux plus récents. Je respecte les bonnes périodes d'apparition des différents transports.
- 3) Je vérifie avec mes différents photocopiés sur les transports si je ne me suis pas trompé(e).

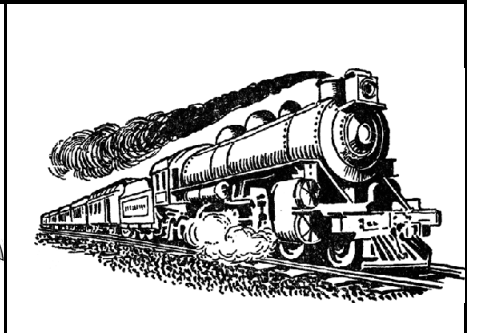
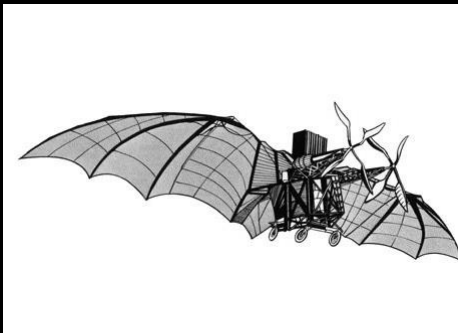
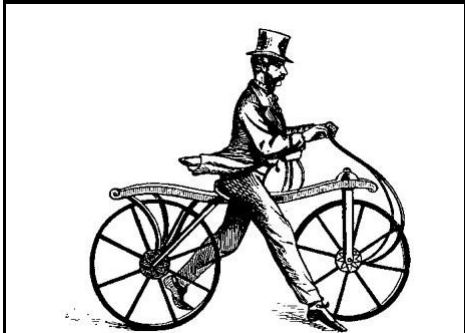
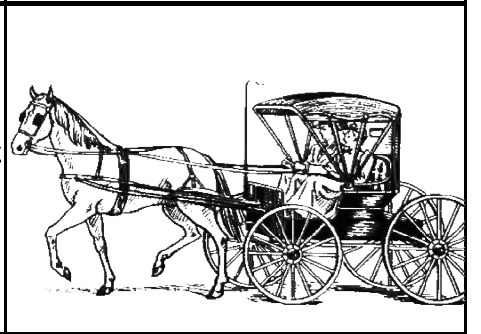
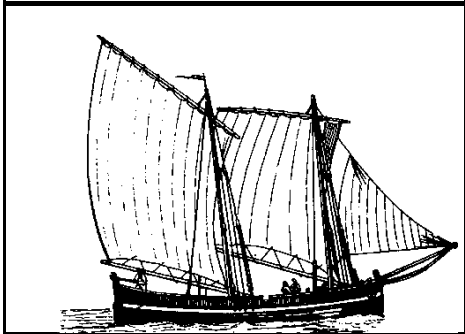
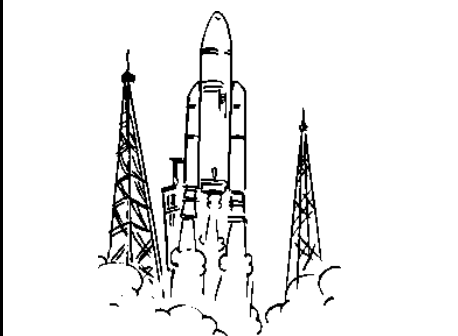
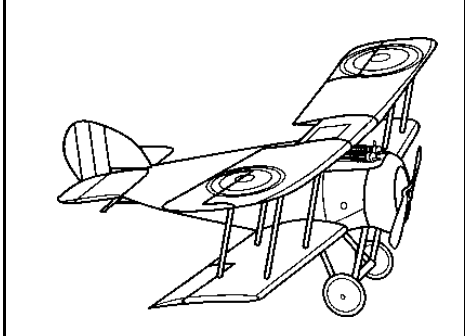
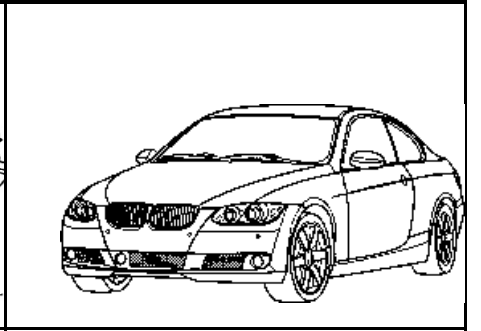
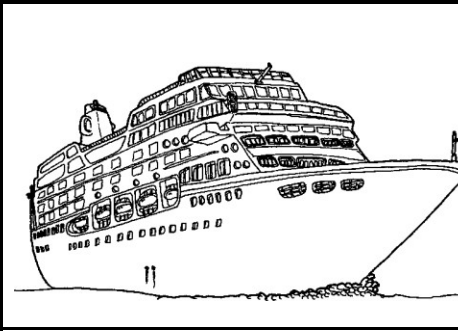
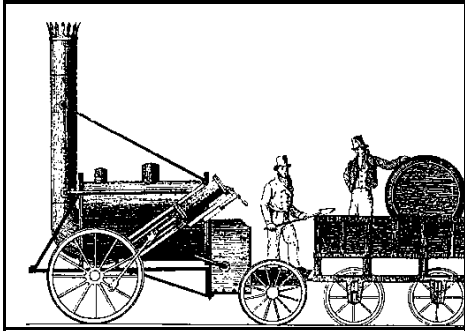
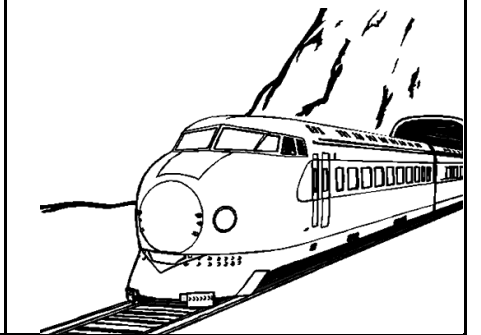
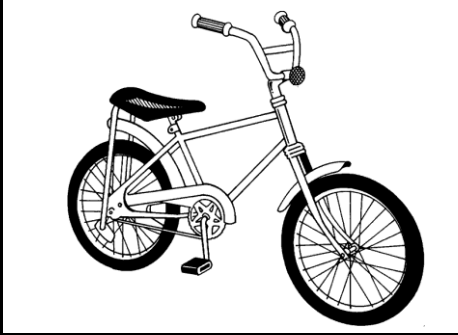
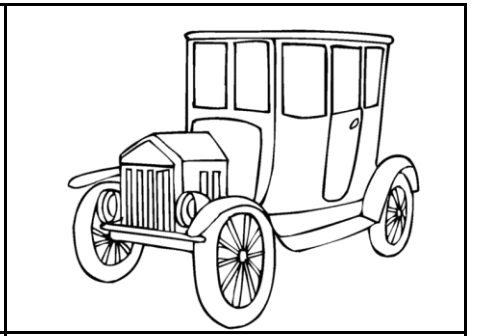
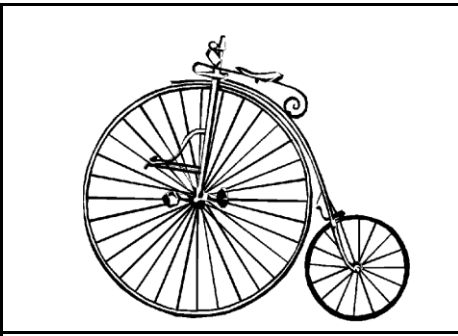
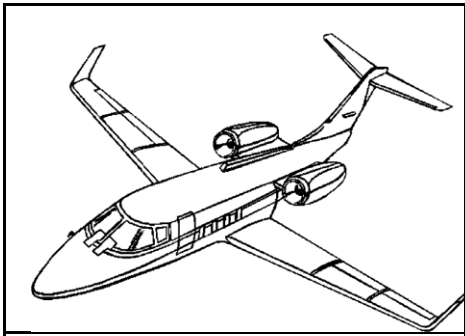

PREHISTOIRE



-3 000 000

ANTIQUITE



-3000

MOYEN



476

